

### FEATURES & BENEFITS

- Minimum energy costs
- Automatic snow melting
- Snow melt only while necessary
- Senses both temperature and precipitation
- Performance optimized for hydronic applications
- Simple installation
- Reliable
- Low cost

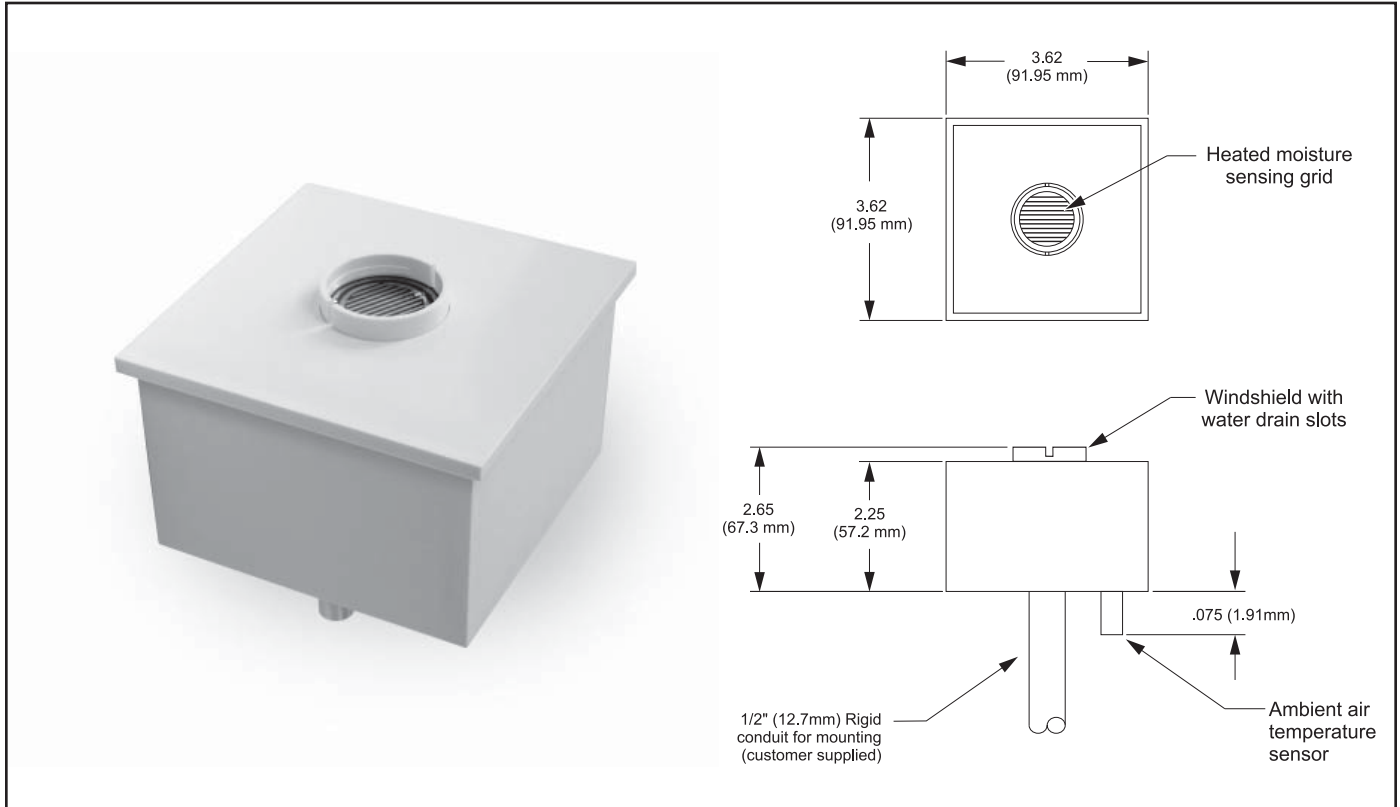

### DESCRIPTION

The LCD-1H & LCD-3H Snow Switch saves energy by providing snow melting only when required during snowfall and for a time thereafter to ensure complete melting.

As heavy, wet spring and autumn snow often occurs above freezing, the LCD-1H & LCD-3H detects precipitation as snow at temperatures below 38°F

(3.3°C). The LCD-1H's internal, isolated 3 amp relay contact remains closed for 5-hour hold-on time after snow fall stops to ensure complete snow melting and pavement drying. The LCD-3H remains closed for 1-hour hold-on time.

The LCD-1H & LCD-3H Snow Switch achieves high performance at low cost through microprocessor

control. Members of the LCD product family have provided more than 70 million hours of reliable snow melting control.

For complete information describing its application, installation and features, please contact Customer Service or check on the web at [www.networketi.com](http://www.networketi.com).

Available at: **631-240-9173**  
**PEXHEAT.COM**

# INSTALLATION

The LCD-1H Snow Switch housing has one 1/2" (16mm) NPT threaded opening. Choose an unobstructed elevated location exposed to snowfall. Rigidly mount in upright, plumb position as shown. Connect the black and white wires to the 24 VAC power supply. Yellow wires are from an isolated 3 Amp resistive/1 Amp inductive relay contact.

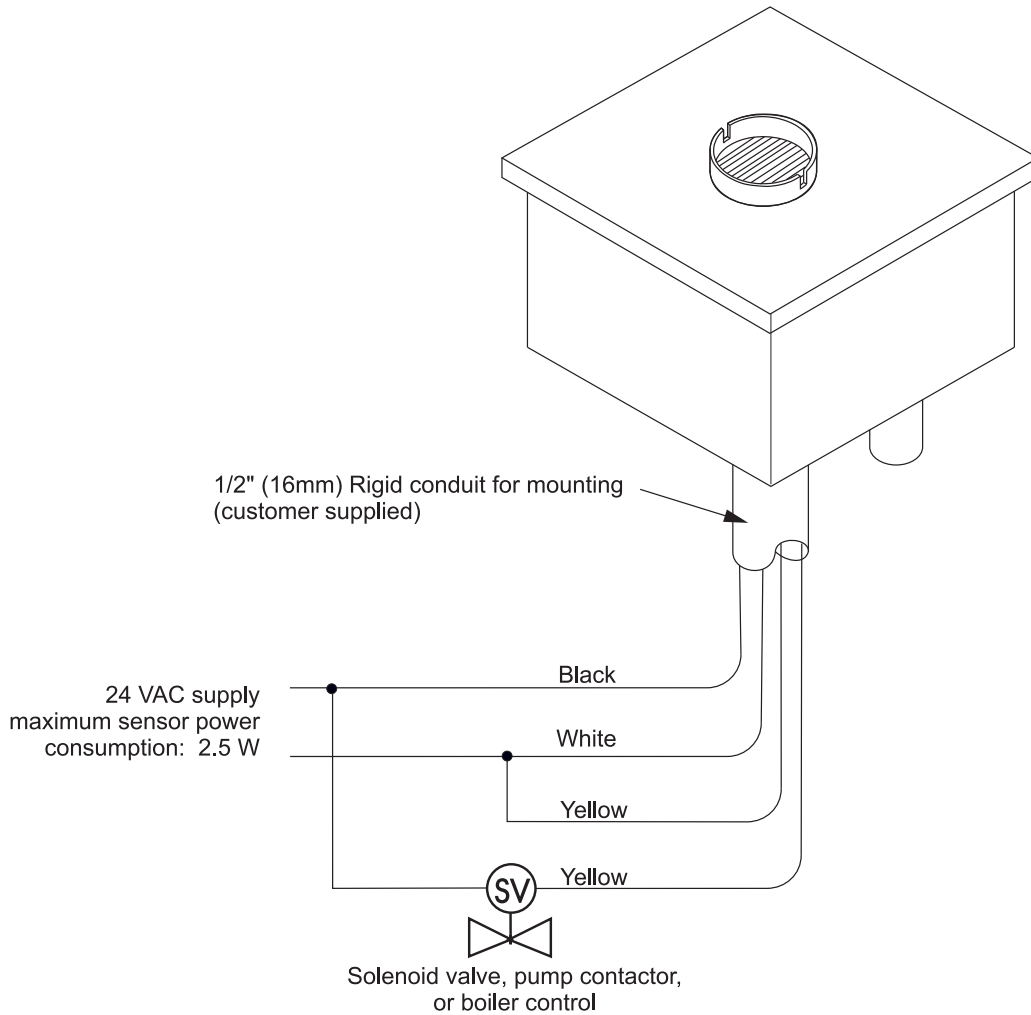

## ORDERING INFORMATION

Order Number	Description
16793	LCD-1H Snow Switch (5 hour hold-on timer)
19435	LCD-3H Snow Switch (1 hour hold-on timer)

## LIMITED WARRANTY

ETI's two year limited warranty covering defects in workmanship and materials applies. Contact Customer Service for complete warranty information.

## DISCLAIMER

Environmental Technology, Inc. makes no representations or warranties, either expressed or implied, with respect to the contents of this publication or the products that it describes, and **specifically disclaims any implied warranties of merchantability or fitness for any particular purpose.** Environmental Technology, Inc. reserves the right to revise this publication, and to make changes and improvements to the products described in this publication, without the obligation of Environmental Technology, Inc. to notify any person or organization of such revisions, changes or improvements.